

# IMPORTANT

HyLoft, Inc. insists on the highest standards of quality in the manufacturing of your products. Each piece has been carefully inspected before shipment. In case of a problem, **DO NOT RETURN THE ITEM TO THE STORE.**

Call HyLoft at:  
1-866-249-5638  
to help with any problem  
or question you may have.

Thank you.



We appreciate your purchase of the HyLoft Shelf System. HyLoft, Inc. has made every effort to supply a quality product that insures a lifetime of trouble-free service. In the event that you have any type of problems and BEFORE RETURNING THE UNIT TO THE SELLER, please call our toll-free number 1-866-HYLOFT (1866-249-5838).

## HyLoft Tire Rack Limited Warranty

HyLoft, Inc. warrants this product against defects in material or workmanship for the life of the product. HyLoft, Inc. agrees to either repair the product or replace it at their sole discretion. This warranty does not include any costs associated with the physical installation, removal or return of the HyLoft product.

**This warranty is valid and enforceable provided that the maximum weight supported by each HyLoft Tire Rack does not exceed 400 pounds, evenly distributed. The customer, dealer, and/or installer releases HyLoft, Inc. of all claims, which includes the HyLoft unit and the structure it is attached to if the loaded weight exceeds 400 pounds. The unit must also be installed according to the manufacturer's instructions. All fasteners must be checked and tightened at least manually.**

Only the original purchaser of this product is extended this warranty. No warranty work will be provided under this warranty without purchaser's receipt or other proof of the date of original purchase acceptable to HyLoft, Inc. Proof of the date of purchase must be provided to HyLoft, Inc. if the product is returned.

This HyLoft, Inc. limited warranty covers product failure due to defects in materials or workmanship ONLY! It does not cover corrosion, rust or discoloration of its components, or product failure due to misuse, abuse, faulty installation, alteration, lack of reasonable care, or any other failure not related to defects in materials or workmanship.

There are NO other warranties expressed or implied except those stated here in as required by applicable law.

HYLOFT, INC. SHALL NOT BE LIABLE FOR INCIDENTAL, SPECIAL OR CONSEQUENTIAL DAMAGES RESULTING FROM THE USE OF THE PRODUCT OR ARISING OUT OF ANY BREACH OF THIS WARRANTY. ALL IMPLIED WARRANTIES, IF ANY, INCLUDING IMPLIED WARRANTIES OF MERCHANTABILITY AND FITNESS FOR A PARTICULAR PURPOSE, ARE LIMITED IN DURATION TO THE DURATION OF THIS WARRANTY. Some states do not allow the exclusion or limitation of incidental or consequential damages, or limitations on how long an implied warranty lasts, so the above exclusions or limitations may not apply to you. No other warranty, written or verbal, will be honored for this product. This warranty gives you specific legal rights and you may also have other rights that vary from state to state.

HyLoft, Inc. is not responsible for damages of merchandise in transit. Repaired or replaced products shall be subject to the terms of this warranty, to be inspected by HyLoft, Inc. prior to return shipment. Damages incurred during transit should be reported at once to the carrier and a claim should be filed with them.

For assistance with your HyLoft storage system or to obtain warranty service, call our Customer Service Department toll-free at 1-866-2-HYLOFT (1-866-249-5638). Please have the product type and date of purchase when you call to avoid delays. Thank You!

HyLoft, Inc. 5175 W. Diablo Drive, Suite 110 Las Vegas, Nevada 89118 USA  
Email: [customerservice@hyloft.com](mailto:customerservice@hyloft.com)

For more information and frequently asked questions, visit our web site: [www.hyloft.com](http://www.hyloft.com)

# Preparation and Safety Information

## IMPORTANT-READ THROUGH ENTIRE INSTRUCTIONS BEFORE BEGINNING INSTALLATION

### Safety:

Read and understand the warning on your stepladder and make sure the ladder is in good working order.

Examine all tools needed to insure they are in proper working order before starting.

Power tools that are not internally grounded require power cords and extension cords with a ground prong.

Always wear eye protection when drilling or installing parts.

HyLoft components are made of metal so beware of any sharp edges and do not let any components make contact with electrical current during installation.

DO NOT install more than one HyLoft unit on the same framing members.

**This unit must be installed on flat walls into wall studs. Do not attempt to install on drywall or on uneven surfaces.**

**Each Tire Rack can hold a maximum of 400 lbs (181 kg). Be sure to distribute the load evenly. Maximum inside opening is 52".**

### Preparation:

The HyLoft unit can be installed in any area of garage, provided there is adequate space. When possible install so that all four sides are accessible for convenient loading.

Take care not to block attic or crawl space access, doorways or lights.

Clear the area where the HyLoft unit is to be installed, and don't leave autos parked near the unit during installation.

Locate any gas, electrical, and plumbing lines in the garage before drilling holes in the drywall.

Installation Time: 30 minutes or less.

**NOTE:** We refer to Wall Studs throughout the instructions. Wall studs are also called Joists or Framing Members.

**HyLoft, Inc., 5175 W. Diablo Drive, Suite 110  
Las Vegas, Nevada 89118 U.S.A.  
e-mail: [info@HyLoft.com](mailto:info@HyLoft.com)**

For more information and frequently asked questions,  
visit our web site: [www.hyloft.com](http://www.hyloft.com)



# ASSEMBLY INSTRUCTIONS

## Tire Rack

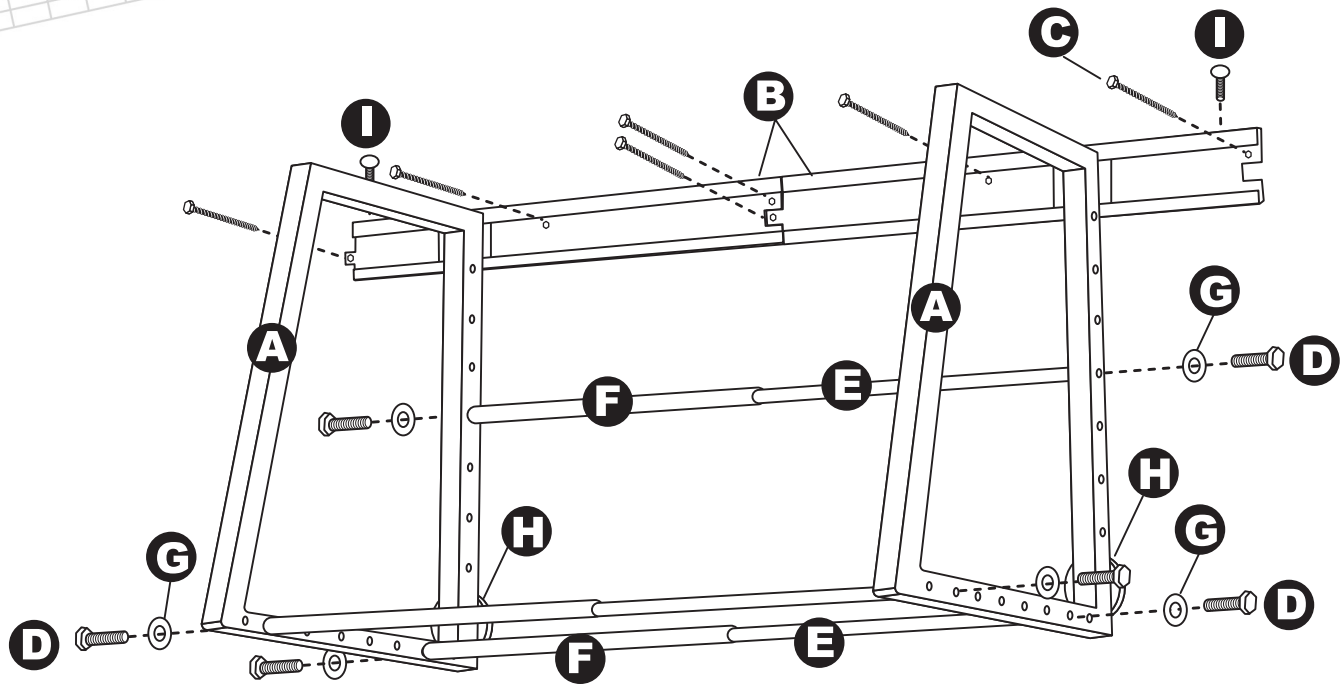

**IMPORTANT-Read through entire instructions before beginning any installation. Check to make sure that you have all parts and tools required.**

### Parts Included:

**A** 2-Side Frames

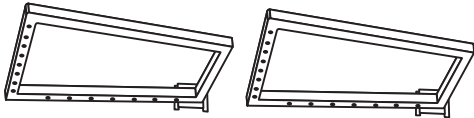

**B** 2-Master Rails

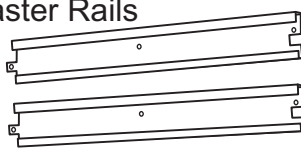

**C** 6-Lag Screws 1/4 x 3"  
(6 x 64 mm)



**D** 6-Hex Head Bolts 3/8"x 2 1/2"



**E** 3-Tubes 1" Dia.



**F** 3-Tubes 1 1/4" Dia.



**G** 6- 3/8" Washers



**H** 2-Rubber Wall Glides



**I** 2-Set Pins

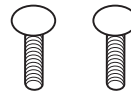

HyLoft Sticker



### Tools Required:



3/16"  
Drill Bit  
(4.8mm)



Power  
Drill



7/16" &  
9/16" Wrench  
(11 mm & 14 mm)

OR



7/16" & 9/16"  
Socket Wrench  
or Nut Driver



Stud/Joist  
Finder  
(optional)



Level



Pencil



Eye Protection



Tape Measure



Ladder or  
Step Stool

MISSING A PART? There is no need to return this item to the store. Instead, call us Toll Free 1-866-2-HYLOFT (1-866-249-5638)

Approximate Assembly Time: 30 minutes or less



## MOUNTING THE MASTER RAILS TO WALL STUDS

- 1A** Using a stud finder, locate 5 wall studs that are 16" center to center apart.  
Note: If studs are not on 16" centers, you may need to drill new matching holes in Master Rails.

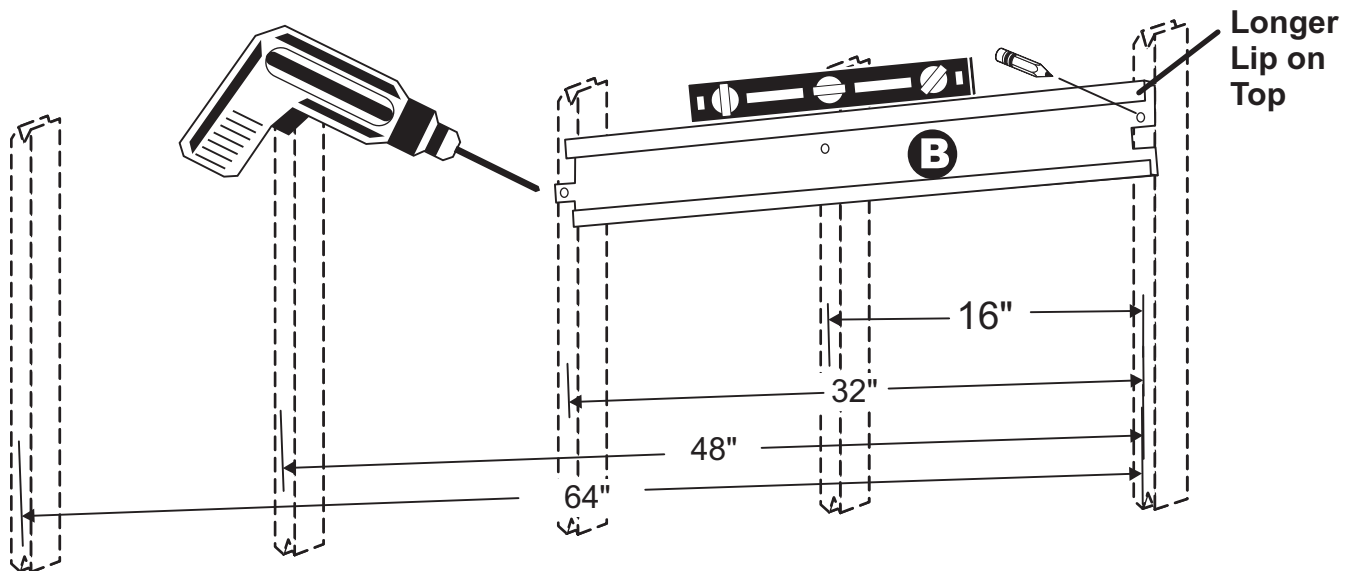

Place one Master Bracket (B) with holes aligned to studs, & verify that Master Bracket is Level. Mark the location of the holes with a pencil. Pre-drill the holes using a 3/16" (5 mm) drill bit. Mount the Master Bracket (B) with 3 Lag Screws (C) using a 7/16" (11 mm) nut driver or socket wrench.

**IMPORTANT:** Master Brackets must be mounted with longer  $\frac{3}{4}$ " lip on top and shorter  $\frac{1}{2}$ " lip on bottom.

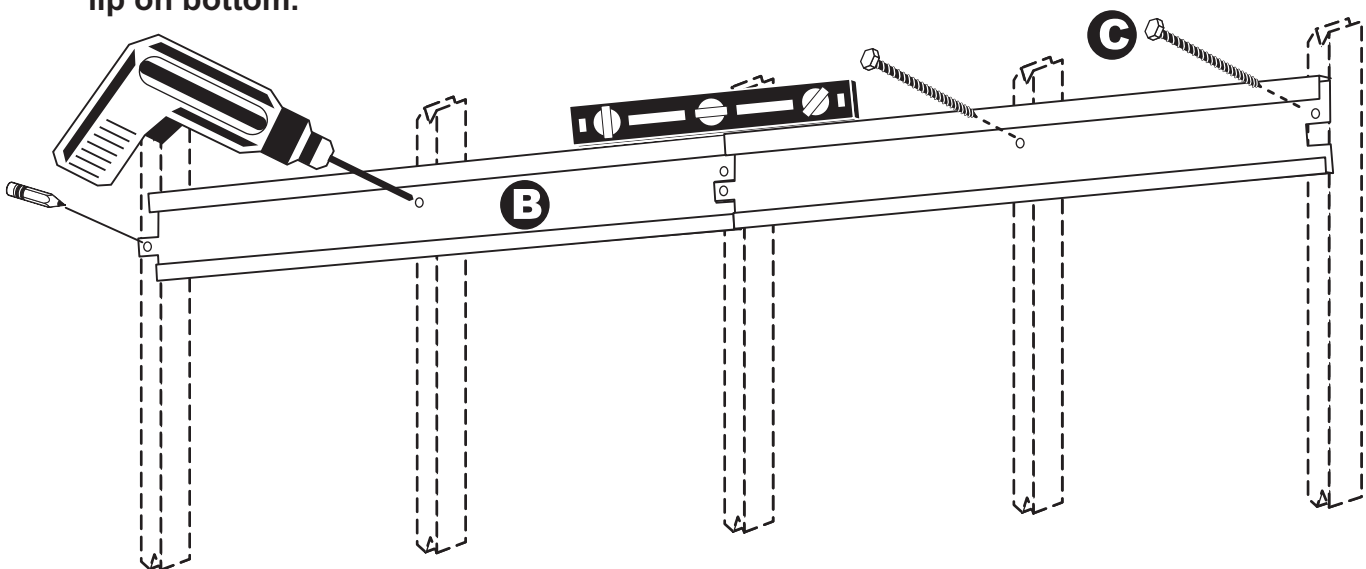

- 1B** Attach 2nd Master Rail (B) by interlocking with 1st and aligning holes with 16" center wall studs. Verify that both Master Rails are level and mark holes with a pencil. Pre-drill the holes using a 3/16" (5 mm) drill bit. Mount the Master Bracket (B) with 3 Lag Screws (C) using a 7/16" (11 mm) nut driver or socket wrench.  
Note: If necessary to mount to uncommon hole patterns, drill new matching holes in Master Rails.

## 2

### ATTACHING THE SIDE FRAMES

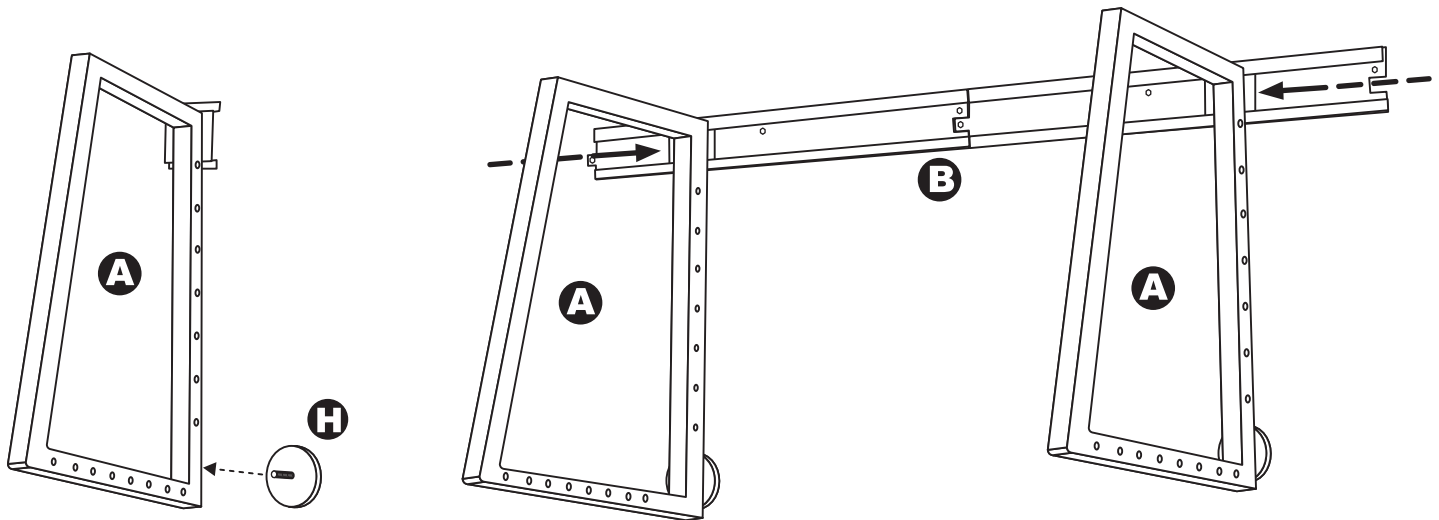

**2A** Attach 2 Rubber Wall Glides (H) to bottom back of both Side Frames (A).

**2B** Slide bracket on top back of Side Frames (A) into ends of Master Bracket (B) until they are the distance apart needed for tire storage. This can be adjusted later at any time.

## 3

### INSTALLING THE SHELF TUBES

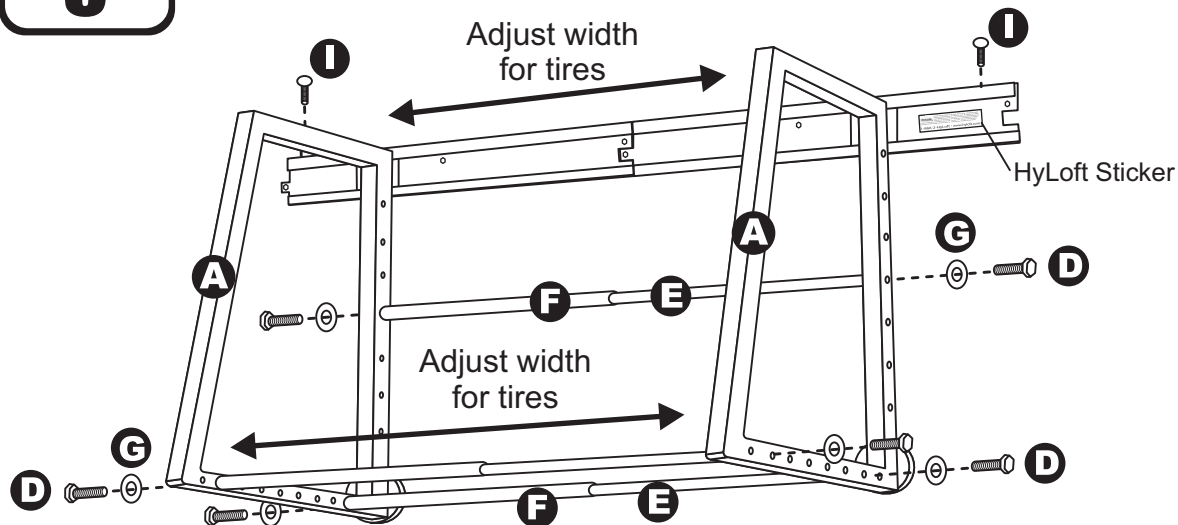

Insert 1" Tube (E) inside 1 1/4" Tube (F) and fasten using Hex Bolts (D) & Washers (G) through Side Frame (A). Start with the back and place at the appropriate height to protect wall from tire rub. Location is determined by tire sizes and can be adjusted to accommodate many sizes.

Insert remaining 1" Tubes (E) into 1 1/4" Tubes (F) and fasten using Bolts (D) & Washers (G) through Side Frame (A). Locate these tubes to accommodate your desired tire size. Tighten all Bolts (D) using a 9/16" (14 mm) nut driver or socket wrench.

Adjust width before adding your tires, and place Set Pins (I) in holes on top of Master Rail in desired location to keep the tire rack from over adjusting in width. This multi-tire rack is designed for a maximum inside opening of 52".

Adhere Hyloft Sticker for convenient access to contact information.

**Each Tire Rack can hold a maximum of 400 lbs (181 kg). Be sure to distribute the load evenly. Do not over extend the inside opening beyond 52".**

Verify all connections at least once per year in order to ensure that they are fastened securely.